

GS SILENCE 20S6 1150X525

THE SILENT ITALIAN MADE HAND PALLET TRUCK



The GS Silenced hand pallettruck has been designed to strongly reduce the noise emission even in the worse working condition: rough and tiled surfaces. The result is an ideal machine for the usage on residential areas deliveries and in supermarket stores

GS SILENCE - PIEK CERTIFIED

In 1998 the Dutch Government set out standards for noise emission during loading and unloading in retail trade and craft businesses. This resulted in a project called PIEK and in 2004 in the PIEK certification scheme for vehicles and equipment operating under 60dB(A) which will be suitable for use in night time deliveries without causing noise disturbance.

The GS SILENCE HPT is PIEK Certified.

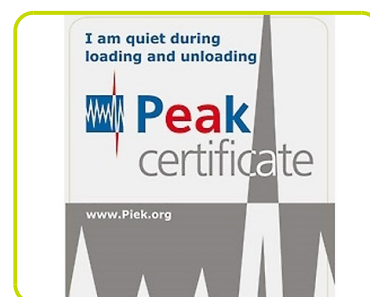

TRIPLE ROLLERS AND REDUCED TOLLERANCES

On order to have a significant sound emission reduction, the HPT is equipped with:

- Triple rollers in SOFT POLIURETHANE (75 Shore)
- Solid push roads
- Zinc plated Clevis with reduced tollerances holes
- Pins with reduced tollerances

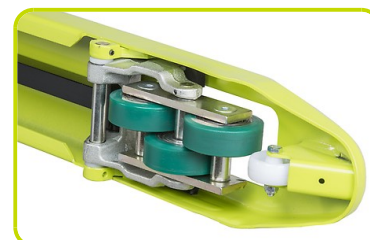

Descriere

1.1 Producător			LIFTER
1.3 Comandă			Manual
1.4 Poziție operare			Pedestru
1.5 Capacitate maximă	Q	Kg	2000
1.6 Distanța la centrul de aplicare al sarcinii	c	mm	600
1.8 Sarcina de la osie la capătul furcilor	x	mm	932
1.9 Ampatament	y	mm	1192

Greutăți

2.1 Greutate de operare		Kg	78
2.2 Sarcină osie, încărcare pe spate		Kg	1472
2.2 Sarcină osie, încărcare pe față		Kg	606
2.3 Sarcină osie, liber spate		Kg	29
2.3 Sarcină osie, liber față		Kg	49

Cauciucuri/Șasiuri

3.1 Cauciucuri: roți direcție			CAUCIUC / ALUMINIU
3.1 Cauciucuri: transportoare cu role			POLY.C
3.2 Mărime cauciuc: roți direcție - Diametru		mm	200
3.2 Mărime cauciuc: roți direcție - Lățime		mm	50
3.3 Mărime cauciuc: transportoare cu role - Diametru		mm	80
3.3 Mărime cauciuc: transportoare cu role - Lățime		mm	30
3.5 Dimensiune cauciuc: roți spate		nr	6
3.5 Dimensiune cauciuc: roți fata		nr	2
3.5 Ax de echilibru spate			No
3.6 Ecartament, față	b10	mm	155
3.7 Ecartament, spate	b11	mm	375

Dimensiuni

4.4 Înălțime stivuitoar	h3	mm	115
4.9 Înălțime manetă în poziția de deplasare, max	h14	mm	1160
4.9 Height of tiller in drive position min	h14	mm	690
4.15 Înălțime, coborât	h13	mm	85
4.19 Lungime globală	l1	mm	1550
4.20 Distanța până la suprafața frontală a furcilor	l2	mm	400
4.21 Lățime globală	b1	mm	525
4.22 Dimensiuni furcă - grosime	s	mm	55
4.22 Dimensiuni furcă - Lățime	e	mm	150
4.22 Dimensiuni furcă - Lungime	l	mm	1150
4.25 Distanța între furci	b5	mm	525
4.32 Gardă la sol și mijloc ampatament	m2	mm	30
4.34 Lățime culoar	Ast	mm	1835
4.35 Rază de virare	Wa	mm	1367

Performante

5.2 Viteză de ridicare, încărcat	strokes		13
5.2 Viteză de ridicare, descărcat	strokes		13

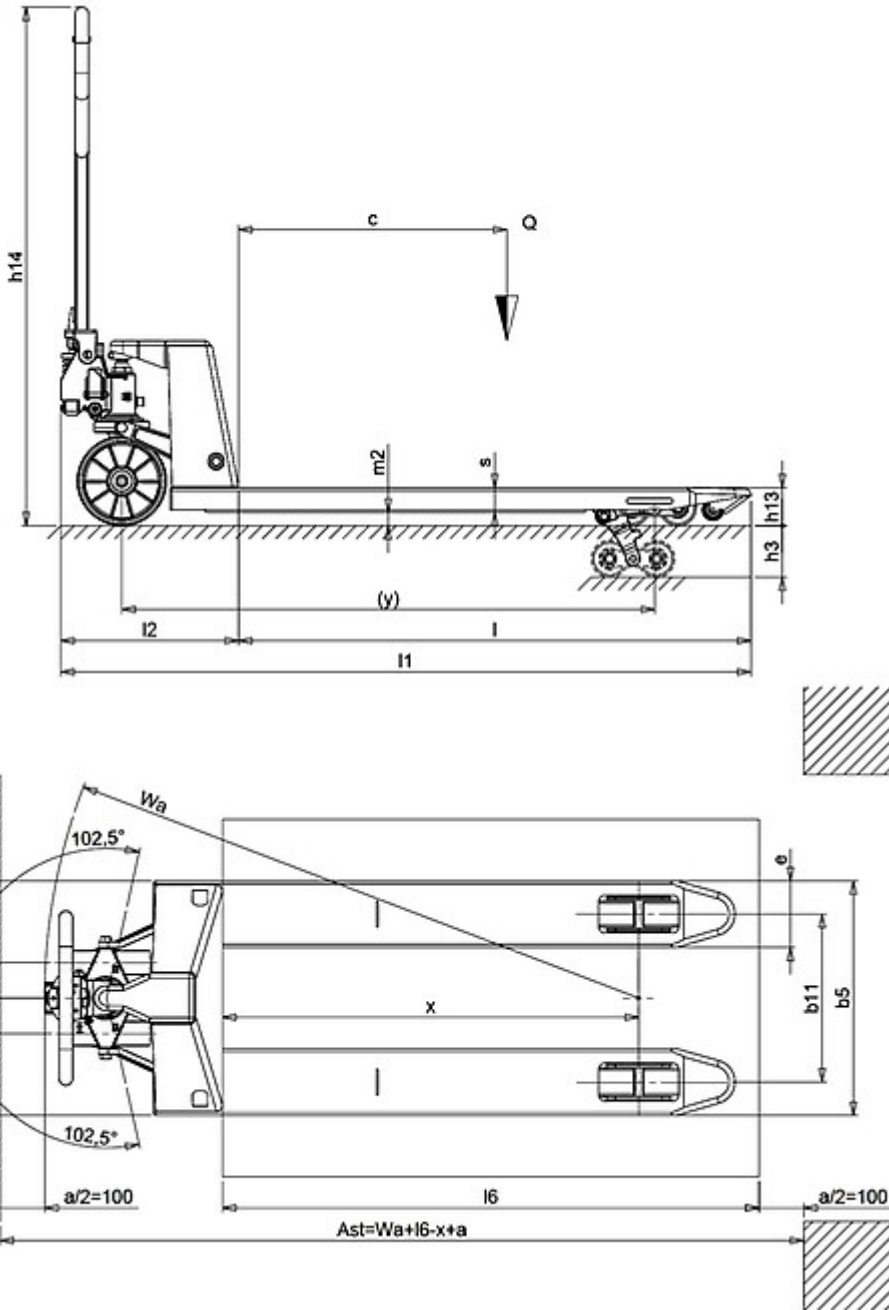

The information is aligned with the Data file at the time of download. Printed on 26/08/2020 (ID 4636)

©2019 | PR INDUSTRIAL s.r.l. | All rights reserved | Image shown may not reflect actual package. Specifications subject to change without notice

