

# QX20 EVO AC S4 1150X540

THE PROFESSIONAL CHOICE



## QX EVO EPT

The new QX is the perfect electric pallet truck suitable for heavy duty applications, ideal for transport over short distances. State-of-the-art proven technology, powerful and reliable motors, excellent manoeuvrability thanks to the compact dimensions, this product is the most competitive solution for your application in medium size warehouses, such as loading/unloading lorries, even in multi shift uses.



## QX20 EVO

QX20 EVO is specifically designed to provide higher performance, reliability and speed through the powerful three-phase AC technology, while reducing noise emission and overheating of the motor wheel. The European made traction battery with 12 DIN elements grants long autonomy and long lifetime.

  
 24V/210Ah    5,6/6 km/h

  
 2000 kg    AC

## ZAPI CONTROLLER

AC technology guarantees more energy efficiency and longer battery charging duration, thus reducing maintenance cost. Furthermore the absence of brushes in the motor and the simpler motor structure increase system reliability.



## TILLER EVOLUTION EPT

Fully integrated ergonomic technopolymer tiller system including fingertip throttle and fork controls, safety pushbutton, horn, turtle button, hourmeter, battery status indicator as standard equipment.



## TURTLE MODE SWITCH

Offered as standard, this function enables operating the truck in confined spaces: it allows the unit to travel with the tiller in upright position.

This function is activated by pressing the turtle button on the tiller and rotating the drive control throttle. The truck travels at limited speed.

Release the button to disable this function.



## SPEED CONTROL

Variable maximum speed depending on the tiller working position increases the manoeuvrability and the safety of the truck.



## BATTERY COMPARTMENT QX

The separate battery compartment allows the installation of high capacity battery (24V/210Ah). The battery inspection is easy and comfortable through the battery cover with hinges. As option automatic battery refilling system can be supplied as the external high frequency battery charger that can be easily plugged through Anderson connector.



## MOTOR WHEEL

Lifting and traction motors have both a voltage of 24 Volt. The vertical assembly not only allows a more rapid access to all the parts but also minimizes room cluttering-up and wiring stress.



## KEY SWITCH AND NOTE HOLDER

The machine is equipped with a key switch placed on an accessible and protected position. The robust battery cover integrates a clip holder for an easy fixing of documents and notes.



## FORKS

Durable and long-lasting fork tips for easy and effortless entry/exit to/from pallet. The machine is offered as standard with heavy duty polyurethane tandem rollers.



## EASY MAINTENANCE

Removing the strong cover allows to have the access to electric and hydraulic system as to the motorwheel and stabilizing wheels.



## BACKREST (OPTION)

Load backrest accessory to guarantee total safety during work, preventing loads falling on operator side.



## Descriere

1.1 Producător			PR INDUSTRIAL
Stivuitoar			ELECTRICĂ
1.3 Comandă			ELECTRICĂ
1.4 Poziție operare			Pedestru
1.5 Capacitate maximă	Q	Kg	2000
1.6 Distanța la centrul de aplicare al sarcinii	c	mm	600
1.8 Sarcina de la osie la capătul furcilor	x	mm	982
1.9 Ampatament	y	mm	1418

## Greutăți

2.1 Greutate de operare		Kg	345
2.1 Greutate de operare (acumulator inclus)		Kg	535
2.2 Sarcină osie, încărcare pe spate		Kg	1580
2.2 Sarcină osie, încărcare pe față		Kg	955
2.3 Sarcină osie, liber față		Kg	430
2.3 Sarcină osie, liber spate		Kg	105

## Cauciucuri/Șasiuri

3.1 Cauciucuri: roți direcție			POLY.C
3.1 Cauciucuri: roți stabilizatoare - Față			POLY.C
3.1 Cauciucuri: transportoare cu role			POLY
3.2 Mărime cauciuc: roți direcție - Lățime		mm	75
3.2 Mărime cauciuc: roți direcție - Diametru		mm	230
3.3 Mărime cauciuc: transportoare cu role - Diametru		mm	85
3.3 Mărime cauciuc: transportoare cu role - Lățime		mm	70
3.4 Mărime cauciuc: roți stabilizatoare față - Diametru		mm	85
3.4 Mărime cauciuc: roți stabilizatoare față - Lățime		mm	48
3.5 Dimensiune cauciuc: roti spate		nr	4
3.5 Dimensiune cauciuc: roti fata		nr	1x+2
3.6 Ecartament, față	b10	mm	498
3.7 Ecartament, spate	b11	mm	370

## Dimensiuni

4.4 Înălțime stivuitoar	h3	mm	120
4.9 Height of tiller in drive position min	h14	mm	715
4.9 Înălțime manetă în poziția de deplasare, max	h14	mm	1200
4.15 Înălțime, coborât	h13	mm	85
4.19 Lungime globală	l1	mm	1748
4.20 Distanța până la suprafața frontală a furcilor	l2	mm	598
4.21 Lățime globală	b1	mm	710
4.22 Dimensiuni furcă - grosime	s	mm	55
4.22 Dimensiuni furcă - Lățime	e	mm	170
4.22 Dimensiuni furcă - Lungime	l	mm	1150
4.25 Distanța între furci	b5	mm	540
4.32 Gardă la sol și mijloc ampatament	m2	mm	30
4.34 Lățime culoar	Ast	mm	2251
4.35 Rază de virare	Wa	mm	1595

**Performante**

5.1 Viteză de deplasare cu incarcare	Km/h	5,6
5.1 Viteză de deplasare fără incarcare	Km/h	6
5.2 Viteză de ridicare, încărcat	m/s	0.051
5.2 Viteză de ridicare, descărcat	m/s	0.06
5.3 Viteză de coborâre, încărcat	m/s	0.032
5.8 Tracțiune maximă în pantă (cu incarcare)	%	8
5.8 Tracțiune maximă în pantă (fără incarcare)	%	16
5.10 Frână de serviciu	ELECTRICĂ	

**Motoare electrice**

6.1 Putere motor comandă	kW	1.1
6.2 Putere motor stivuitor	kW	0.84
6.4 Tensiune acumulator	V	24
6.5 Greutate acumulator, min	Kg	190
6.5 Greutate acumulator, max	Kg	190
8.4 Nivel sonor la nivelul urechii șoferului	dB(A)	74

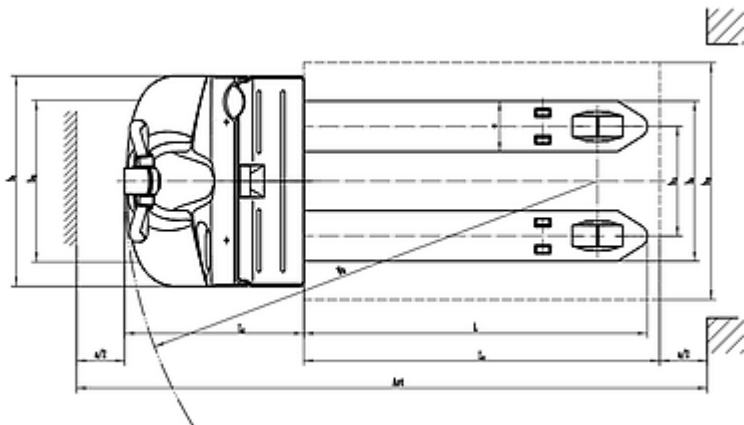
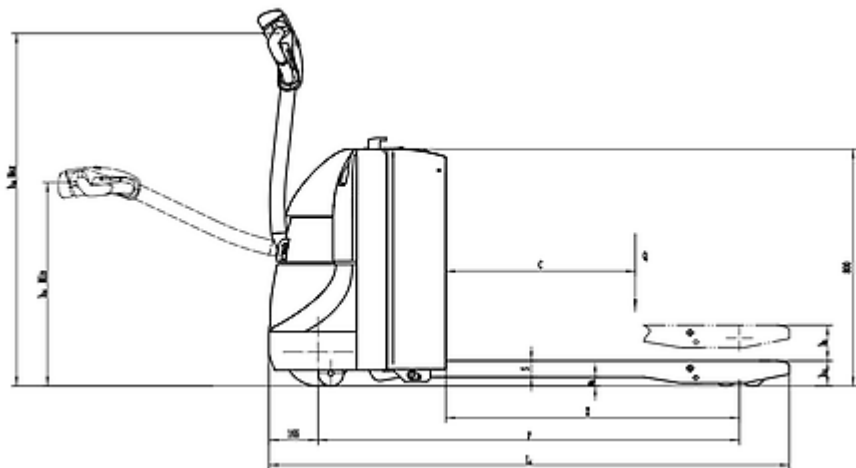

The information is aligned with the Data file at the time of download. Printed on 26/08/2020 (ID 10705)

©2019 | PR INDUSTRIAL s.r.l. | All rights reserved | Image shown may not reflect actual package. Specifications subject to change without notice

